

# HEATSTRIP<sup>®</sup>

RADIANT OUTDOOR HEATERS



## Product Manual



### HEATSTRIP<sup>®</sup> Max-DC with Remote (THX-DCR)

*Take Heating to the Max!*





## Product Overview

Rev A MAR 21

### Why choose HEATSTRIP® electric radiant heaters for your outdoor or hard-to-heat indoor area?

As there is typically constant air movement in an outdoor or open indoor area, many conventional heaters rely on convection heating which works by heating the surrounding air. This can be quite impractical for these areas, as this heated air can easily blow away with natural air movement. Radiant style heaters transfer heat directly to objects through infra-red waves.

Whilst convection heaters heat the air in between objects, radiant heaters heat the surface of the objects themselves. HEATSTRIP® electric radiant heaters are more effective within an outdoor or uninsulated indoor area because they provide targeted warmth directly to the people and objects in their path.

### Innovative, High Performance Electric Heating Technology — for outdoor and indoor areas

Using the radiant heating principle, HEATSTRIP® Max DCR can provide effective and energy efficient comfort heating for outdoor (undercover and open) and indoor open areas. HEATSTRIP® has successfully enabled many entertainment venues such as restaurants, pubs and clubs to utilise their outdoor dining areas day and night, through all seasons. Within your workplace or business, HEATSTRIP® can provide comfort heating for designated outdoor smoking and leisure areas, as well as for workstation spot heating in factories, warehouses and showrooms. Within your home, HEATSTRIP® can provide comfort heating for undercover alfresco dining and BBQ area, patios, verandas, courtyards and balconies.

There are 5 different ranges within the electric HEATSTRIP® product category. Each has a different temperature rating making them suited to a variety of applications. Below is a list of some common applications, to assist with the selection of the most effective and efficient series. This is a general guide only, please refer to the Product Manual for each product, for more information.

**HEATSTRIP® Indoor** (THS-A models) is a medium intensity heater used for protected indoor applications only with installation heights up to 2.5m (THS800A) or 2.7m (all other THS-A models).

**HEATSTRIP® Classic** (THH-A & THH-AR models) is a premium high temperature heater and is primarily used for protected outdoor areas with an ideal mounting height of 2.3m to 2.5m and maximum mounting height of 2.7m.

**HEATSTRIP® Elegance** (THE & THE-R models) is a premium high temperature heater and is primarily used for protected outdoor areas with an ideal mounting height of 2.3m to 2.5m and maximum mounting height of 2.7m.

**HEATSTRIP® Max** (THX or THXDCR models) is an ultra high temperature heater used for uncovered or open indoor or outdoor areas with an ideal mounting height of 2.3 m to 2.7m, and up to a maximum 3.5m for protected indoor applications.

**HEATSTRIP® Intense** (THY models) is an instant high temperature heater perfect for any exposed outdoor or indoor areas with an ideal mounting height of 2.3m to 2.8m, and a maximum of 3m in an outdoor exposed application.

APPLICATION	THS	THH THE	THX	THXDCR	THY
Indoor insulated areas: classrooms, offices, bathrooms, wet areas, drying rooms	√	√			√
Outdoor under cover: café, veranda, patio, balcony ceiling height 2.7m or less		√	√	√	√
Outdoor under cover: café, veranda, patio, balcony ceiling height 2.7m or more			√	√	
Highly exposed outdoor area			√	√	√
Indoor open area: warehouse, factory, production areas, sports facilities	√	√	√	√	√
Indoor spot heating, above tables, assembly areas		√	√	√	√



## Innovative, High Performance Electric Heating Technology

### Features & Benefits

#### High Output radiant heat

The HEATSTRIP Max DCR range of electric radiant heaters produces a high temperature radiant warmth that travels through the air directly to people and surfaces below – similar to the heat rays emitted by the Sun. Radiant heating is the only viable option for outdoor or tough indoor sites.

#### Dual Glass Element Design

Specially designed and engineered with a dual glass elements, which deliver high intensity instant heat. Ideal for coastal or hard to heat applications.

#### Maximum heat performance – multiple applications

The high temperature output of the HEATSTRIP Max DCR is perfect for exposed outdoor sites, high ceilings and hard-to-heat indoor and outdoor applications.

The dual element design allows for a very compact unit, and maximum efficiency. Outdoor applications include al-fresco and dining/entertainment areas, patios, veranda's and balconies, to name a few. Indoor applications such as factories, warehouses, showrooms, workshops and workstation spot heating are ideal for the HEATSTRIP Max DCR.

#### Suitable for permanent outdoor mounting, no protection needed.

For outdoor applications, the HEATSTRIP Max DCR is suitable for both permanently exposed (eg. courtyards and patios) and undercover installations - does not need to be fully protected from the elements.

#### 2 years full replacement warranty

It is fully supported by a 2 year replacement warranty under both residential and commercial conditions.

#### Corrosion protection

The HEATSTRIP Max-DC with Remote is suitable for use in most applications, including difficult corrosive environments such as coastal areas.

#### Multi-Purpose Mounting Options

The HEATSTRIP Max DCR is supplied with flexible mounting options. The standard bracket will allow both ceiling and wall mounting, at various angles, as well as suspension by chains/wires. Extension rods and flush mounts are available as optional accessories.

#### 2 models – DIY or hard-wired

2 models are available. The THX2400DCR (2400W) is supplied with a lead and plug, therefore ideal for a DIY installations. The THX3600DCR (3600W) requires hard-wiring to a 15amp power supply.





## Specifications - Australia

MODEL	POWER (WATTS)	CURRENT (AMPS)	DIMENSIONS (mm) (L x W x D)	WEIGHT (Kg)	LEAD LENGTH (mm)	PLUG
THX2400DCR	2400	10	983 x 170 x 80	6	1000	YES
THX3600DCR	3600	15	1180 x 170 x 80	8	1000	NO

MODEL	
HEATER TYPE	High intensity electric radiant, infra-red overhead heater with dual glass element
OUTPUT	Refer to model code chart above
POWER	230-240 Volts Nominal at 50—60 Hertz, Single Phase
CONNECTION	3 Core Cable 2.5mm <sup>2</sup>
APPROVALS	AUSTRALIA / NZ
MOUNTING HEIGHT	MINIMUM 2.1 m RECOMMENDED 2.3 m to 2.8 m MAXIMUM 3.0m Outdoors and 3.5m Indoors (For higher ceiling heights, units can be lowered using optional bracket kits)
MOUNTING OPTIONS	Suitable for ceiling, wall, beam mounting. Also available for extension mount using rigid fixing poles, chain mount bracket & flush mounting.
PROTECTION RATING	IPX5 Protection from water ingress from all directions
MATERIALS OF CONSTRUCTION	Anodised alloy casing and end caps with a powder coated grille (Black)

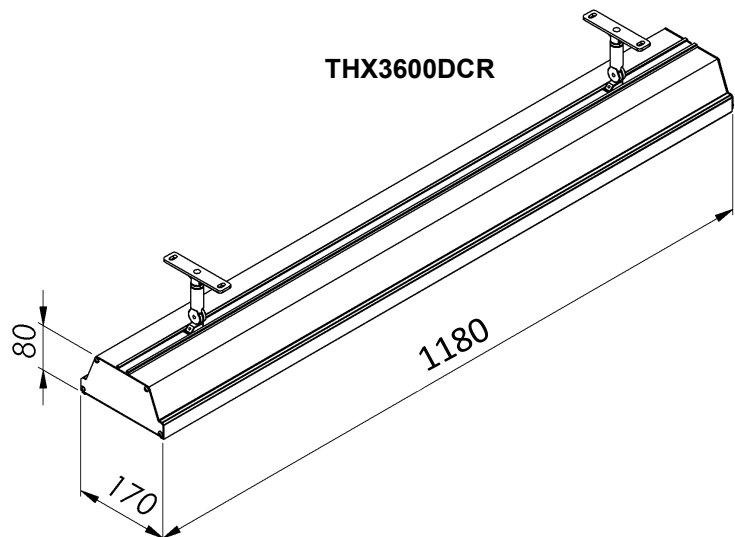
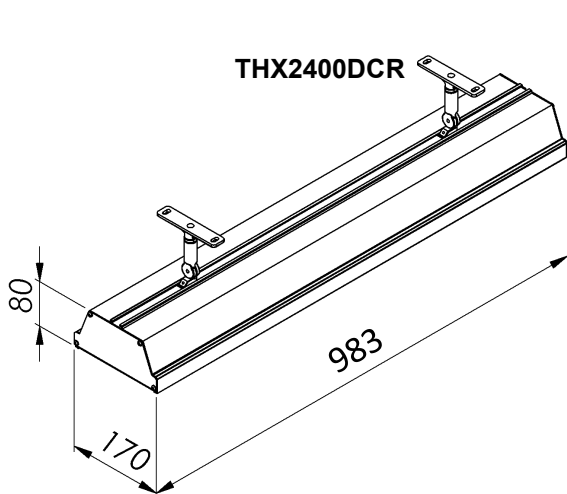



## Spot heating principle

In most outdoor or difficult-to-heat indoor applications, there are 2 methods when looking at the size and quantity of heaters required.

**Option 1** is to comfort heat the entire area based on the total dimensions of the space, regardless of whether the entire area is being fully occupied or not.

**Option 2** is to spot heat the high use areas, such as over outdoor tables, BBQ's, lounges, assembly lines or indoor workstations.

Often it is more practical and efficient to spot heat these areas. Spot heating will help to reduce the initial capital cost, as well as the on-going running costs. Spot heating will allow the area to be "zoned", meaning heating only the areas that are being used, such as tables in a restaurant or outdoor alfresco area.

The top diagram shows how HEATSTRIP® Max DCR is recommended to be used directly over a table, while the bottom diagram indicates how to spot heat a large area.

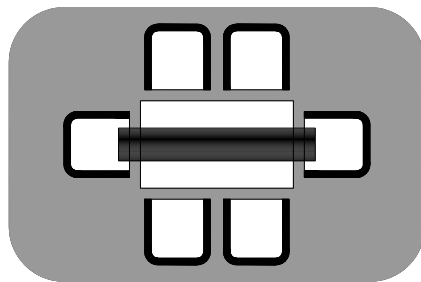

THX2400DC-R

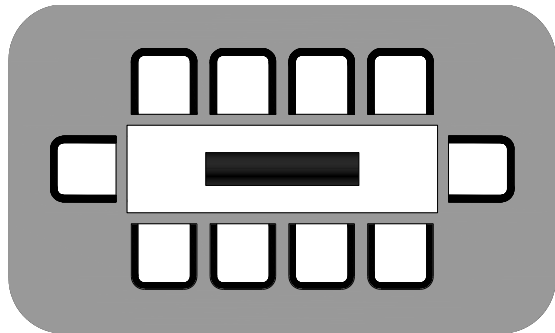

THX3600DC-R

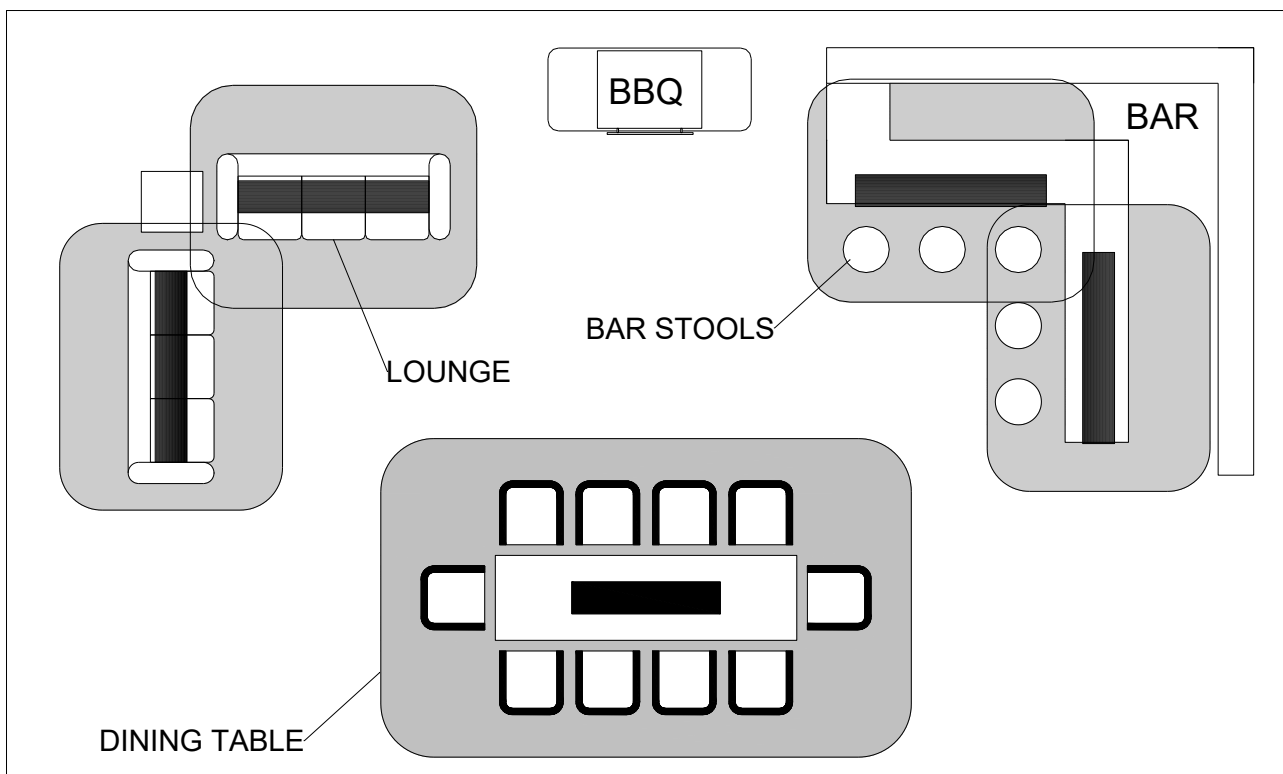



## Radiant footprint

HEATSTRIP® Max DCR electric heaters produce radiant heat, which heats objects rather than the air. Therefore, it is imperative that objects to be heated (ie. people), are within the direct radiant footprint of the heater.

The diagram below shows the radiant footprint of HEATSTRIP® Max DC-R, and is an approximate guide based on a fully enclosed, outdoor environment.

This diagram shows that the maximum heat output is found directly under the heater, and the temperature decreases as you move away from the heater.

It highlights the importance of maintaining recommended mounting heights, and positioning the heater directly above the area to be heated, if possible.

Also, the temperature (ie. surface temperature) is the same for both models, regardless of the wattage. However, as the size increases and the length of the unit increases, the radiant footprint will be larger.

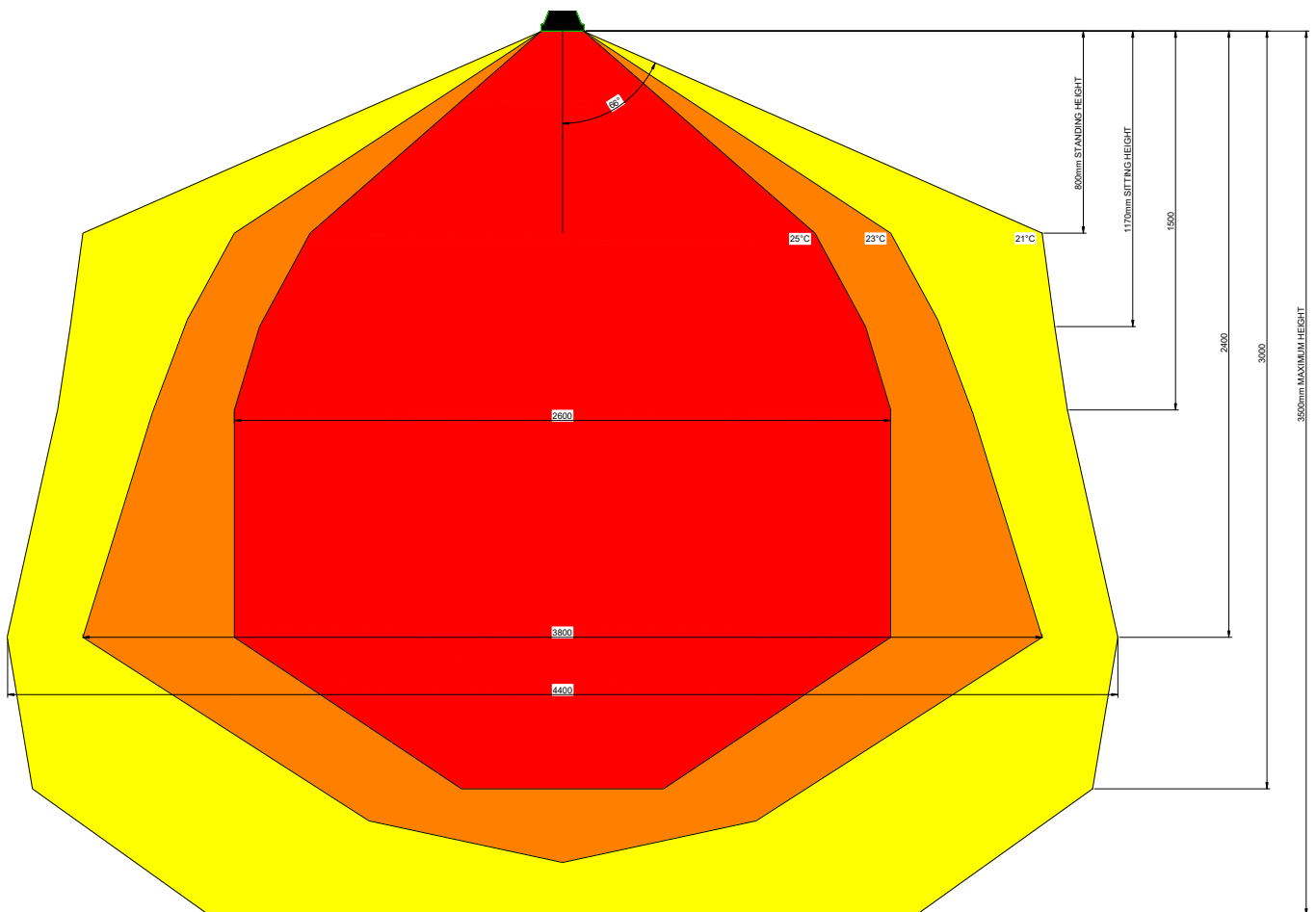



## Selection guide

General recommendations for **HEATSTRIP® Max DC with Remote:**

- Ideal mounting height: 2.3m to 2.8m. Maximum is 3.0m Outdoors and 3.5m Indoors
- Ideal mounting location: ceiling mounted, directly above area to be heated (Eg. above a table)

The below table outlines the coverage of each HEATSTRIP® Max DCR model (in m<sup>2</sup>), based on 3 different scenarios. For example, in an outdoor area that is protected from prevailing winds by walls, café blinds etc, (eg outdoor enclosed), Model THX2400DC-R will cover 12m<sup>2</sup> and Model THX3600DC-R will cover 18m<sup>2</sup>.

This data is based on direct overhead ceiling mounting. If the heaters are wall mounted, the radiant footprint will be reduced.

MODEL	INDOOR PROTECTED (m <sup>2</sup> )	OUTDOOR ENCLOSED (m <sup>2</sup> )	OUTDOOR EXPOSED (m <sup>2</sup> )
THX2400DC-R	19	12	7
THX3600DC-R	29	18	10

Above data is based on direct overhead ceiling mounting. If the heaters are wall mounted, the radiant footprint may be reduced.

The below diagrams show the approximate heating area for each model, based on both an indoor protected, outdoor enclosed and outdoor exposed location.

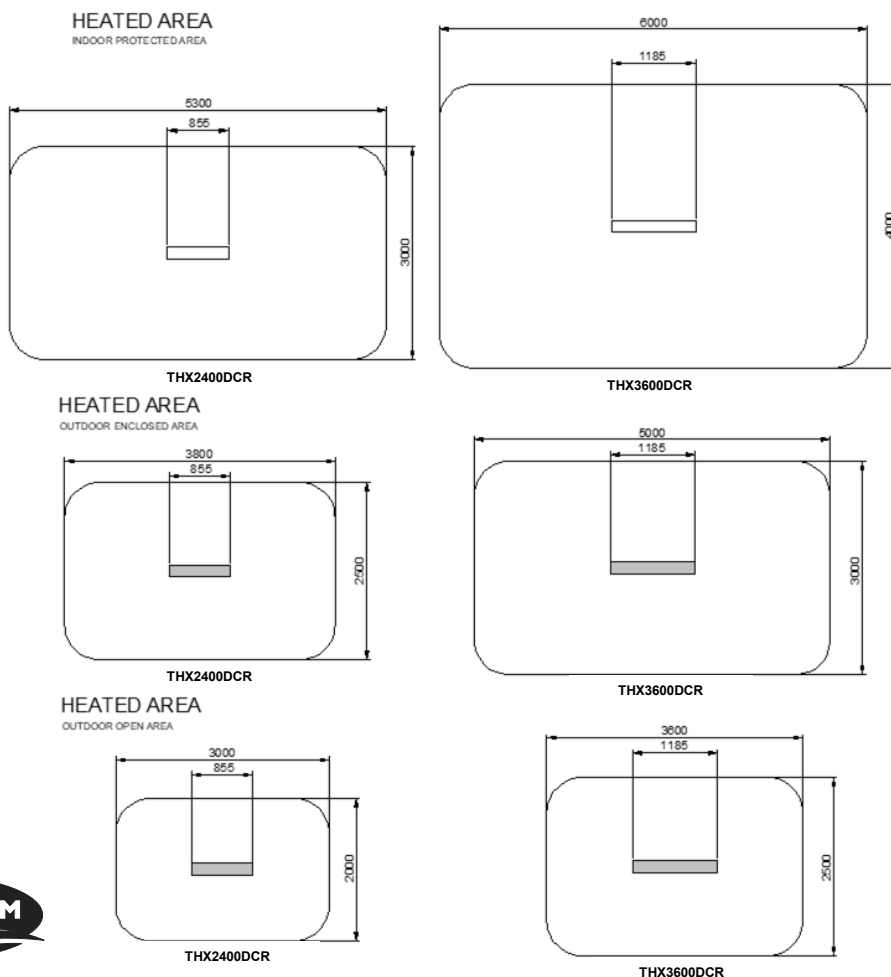



## Table layout

For the majority of outdoor applications, the most effective method is to spot heat a table or similar area. The below diagrams provides an easy selection guide for the approximate model and quantity of heaters required to heat common residential table settings.

Selections are based on HEATSTRIP® Max DC with Remote being mounted at 2.7m from the floor and an undercover fully enclosed outdoor area.

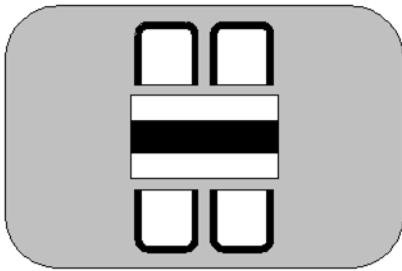

THX2400DCR

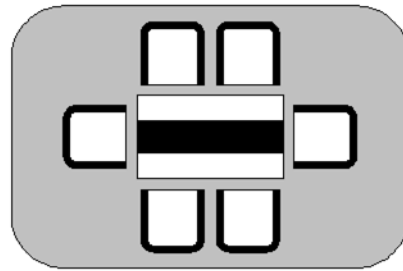

THX2400DCR

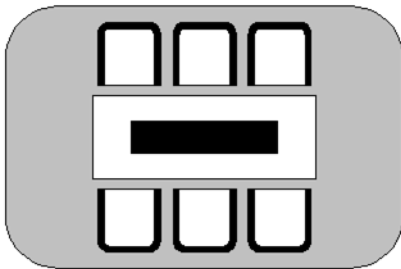

THX2400DCR

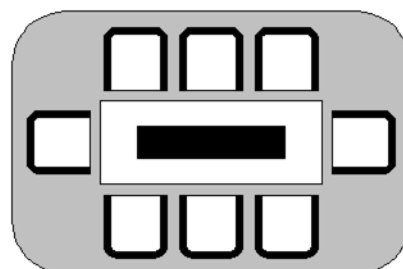

THX2400DCR

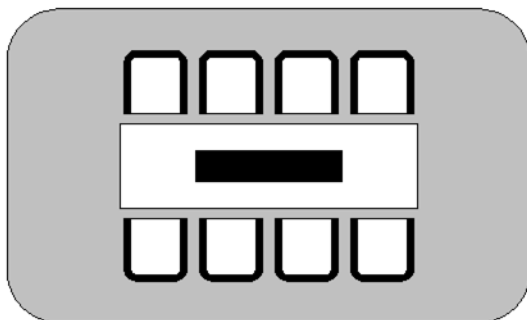

THX3600DCR

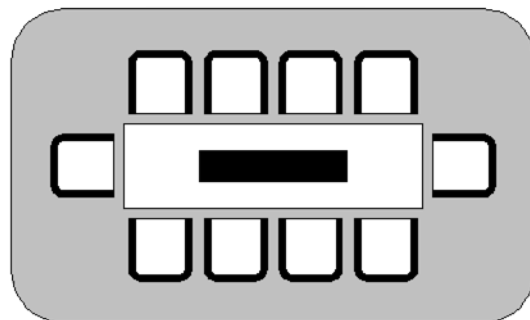

THX3600DCR

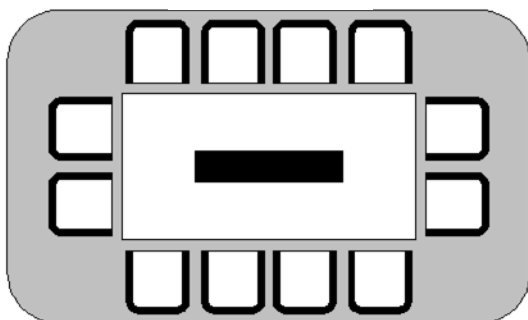

THX3600DCR

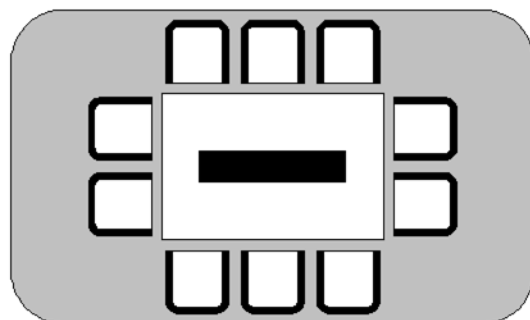

THX3600DCR





## Installation Requirements

The ideal mounting position for the HEATSTRIP® Max DC with Remote is on the ceiling, directly above the area to be heated. If this is not possible, HEATSTRIP® Max DC with Remote can be mounted on a wall and angled downwards. In this situation, ensure the mounting height is in the range of 2.3m to 2.8m and the table is within 1-2m of the wall.

For mounting heights more than 3.0m outdoors, we recommend the use of the optional accessories to reduce the height of the heater to 2.3m—2.8 m. This will increase the effectiveness of your HEATSTRIP®. Refer to the Mounting Accessory section for more information.

Electrical connections/GPO's should not be located at the back of the heater. They should be located outside the physical footprint of the units to minimize heat build-up behind the units.

**The HEATSTRIP® Max DC With Remote is not suitable for mounting on an incline, along the length.**

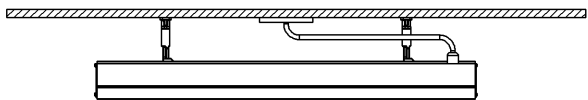
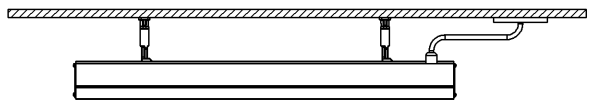
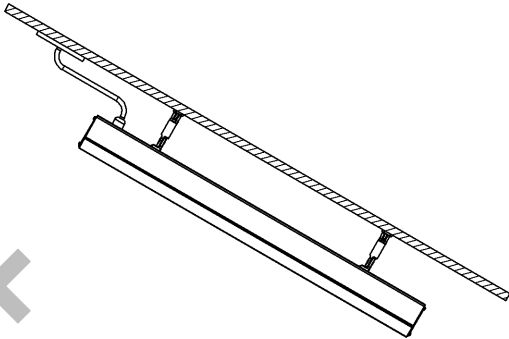
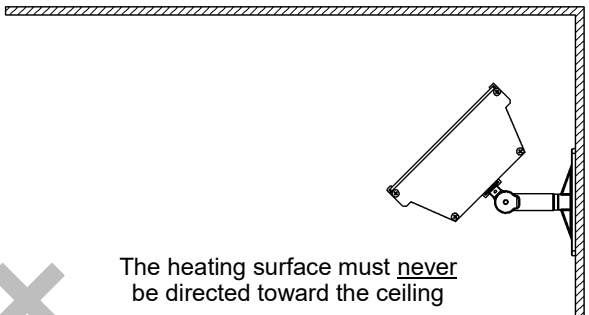
Incorrect Installation	Correct Installation
 <p data-bbox="178 1093 258 1173">✘</p>	 <p data-bbox="833 1093 912 1173">✔</p>
 <p data-bbox="178 1464 258 1545">✘</p>	
 <p data-bbox="178 1877 258 1957">✘</p> <p data-bbox="312 1868 657 1921">The heating surface must <u>never</u> be directed toward the ceiling</p>	



**Installation location** — the below diagrams confirm the minimum recommended clearances.

**Angled Wall Installation**

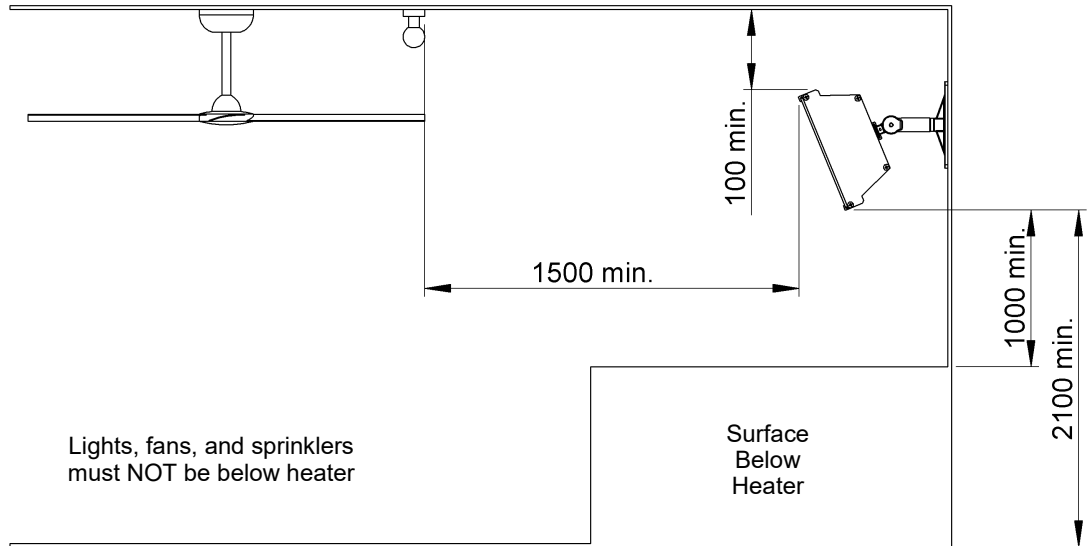

**Ceiling Installation**

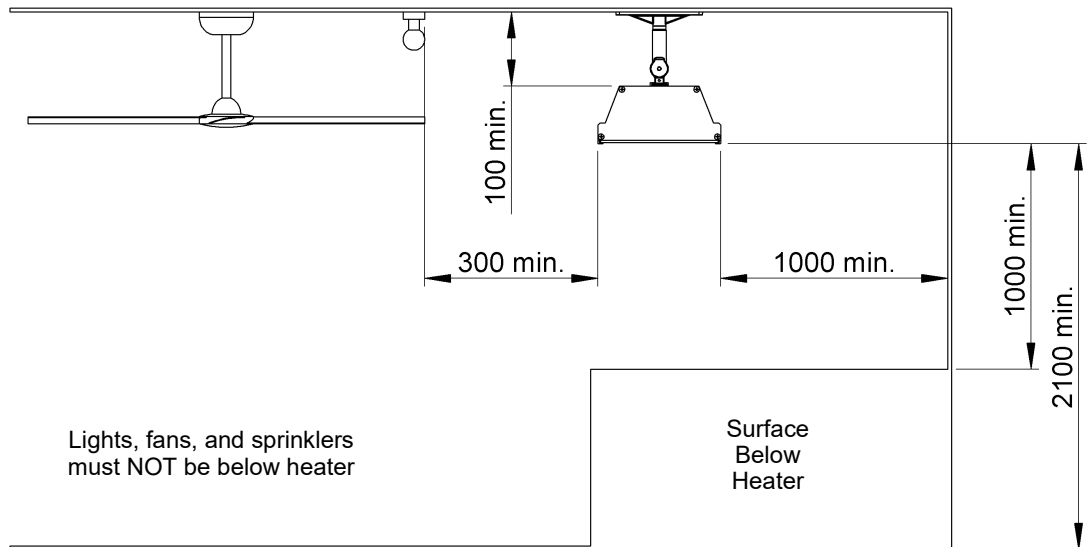

**Angled Ceiling Installation**

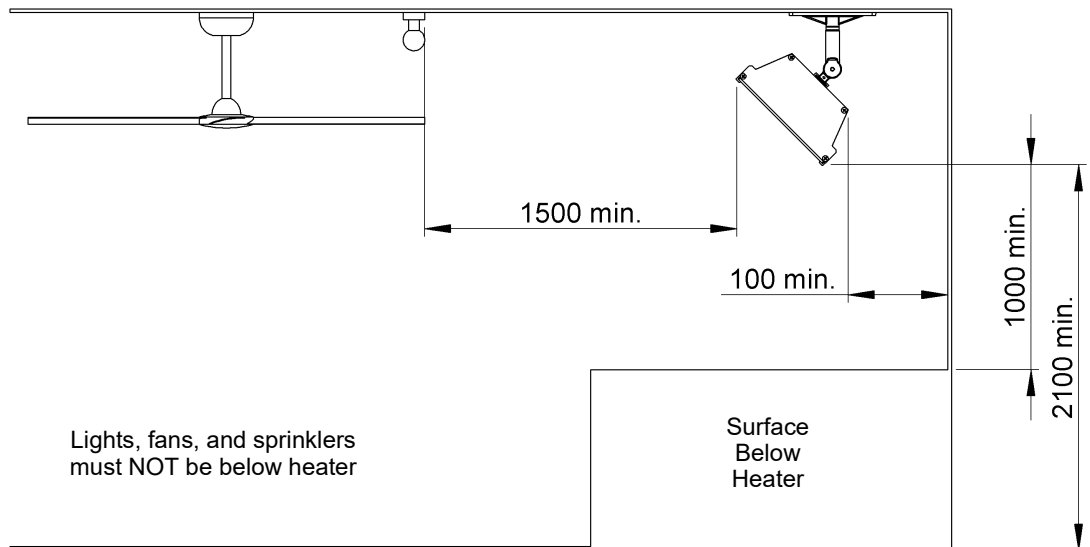



## Mounting options

The installation of HEATSTRIP® Max DCR is simple and easy with the standard mounting brackets supplied. For other more challenging locations there are a range of mounting options available - refer to below diagrams.

The HEATSTRIP® Max DCR can be mounted directly to the ceiling, angled downwards on a wall, suspended on chains or poles, or attached to beams or poles. Refer to the following pages for more detailed information on each mounting option.

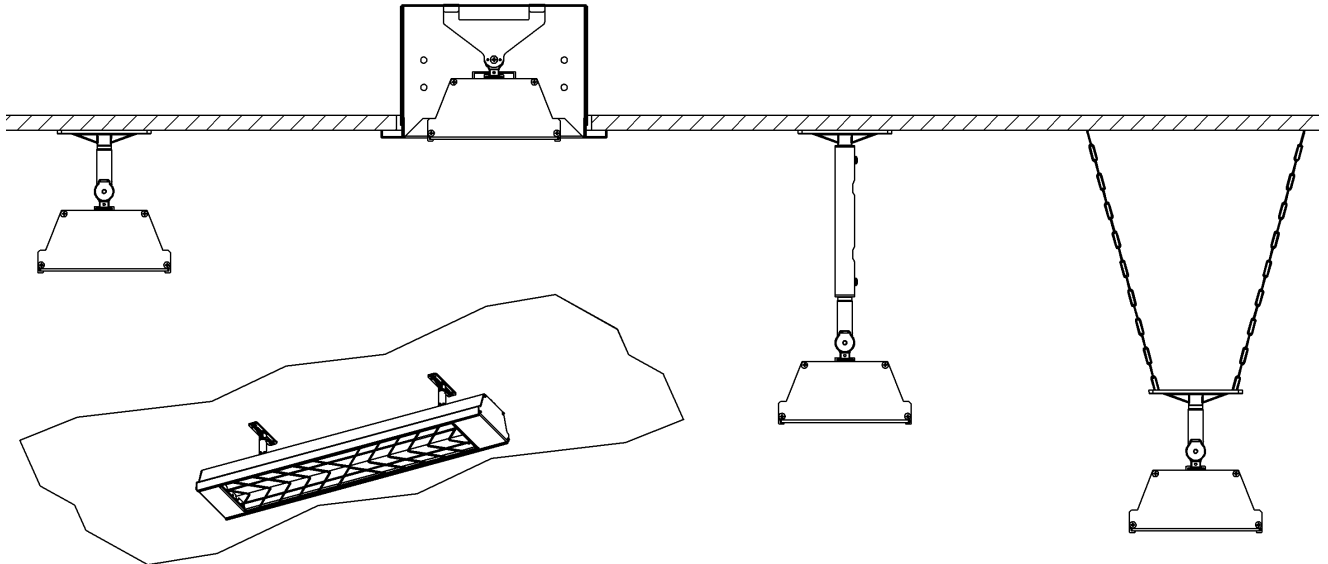

Standard Ceiling Bracket

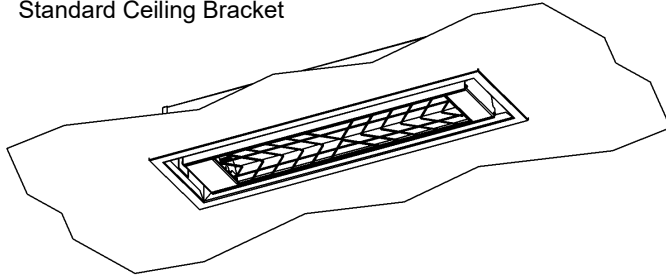

Flush Mount Enclosure

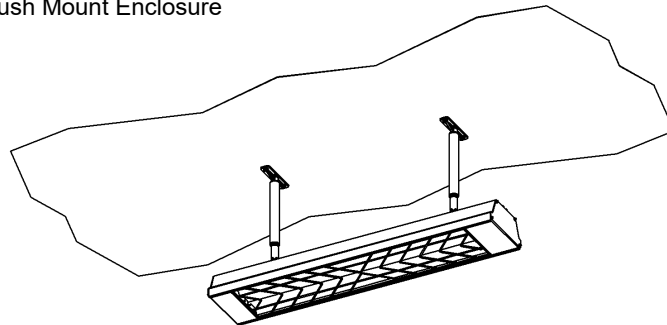

Extension Mounting Bracket

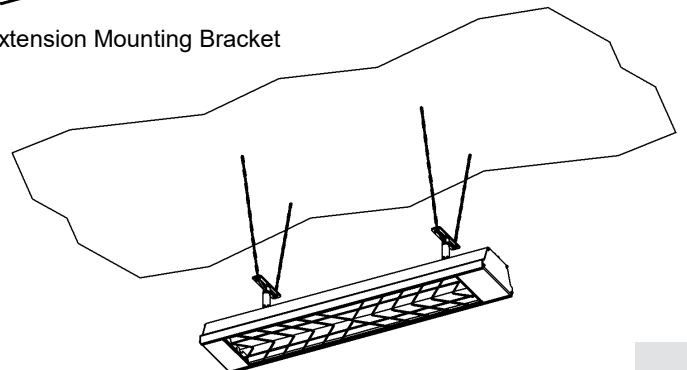

Chain / Wire Mounting



## Standard mounting brackets

The HEATSTRIP® Max DCR comes with a pair of standard mounting brackets. These adjustable brackets allow direct ceiling or wall mount, and come with pre-set angle options of parallel, 22.5° and 45°.

The flexible standard mounting bracket can be turned 90 degrees to mount onto a beam, it can also be used to suspend with chains.

The brackets need to be mounted onto a secure frame or wall with a minimum distance between the two brackets. The minimum distance ("B") for each model is listed on the next page.

When completing the installation, ensure all screws are tight and unit is secure.

Note: When suspension mounting, chains are not included.

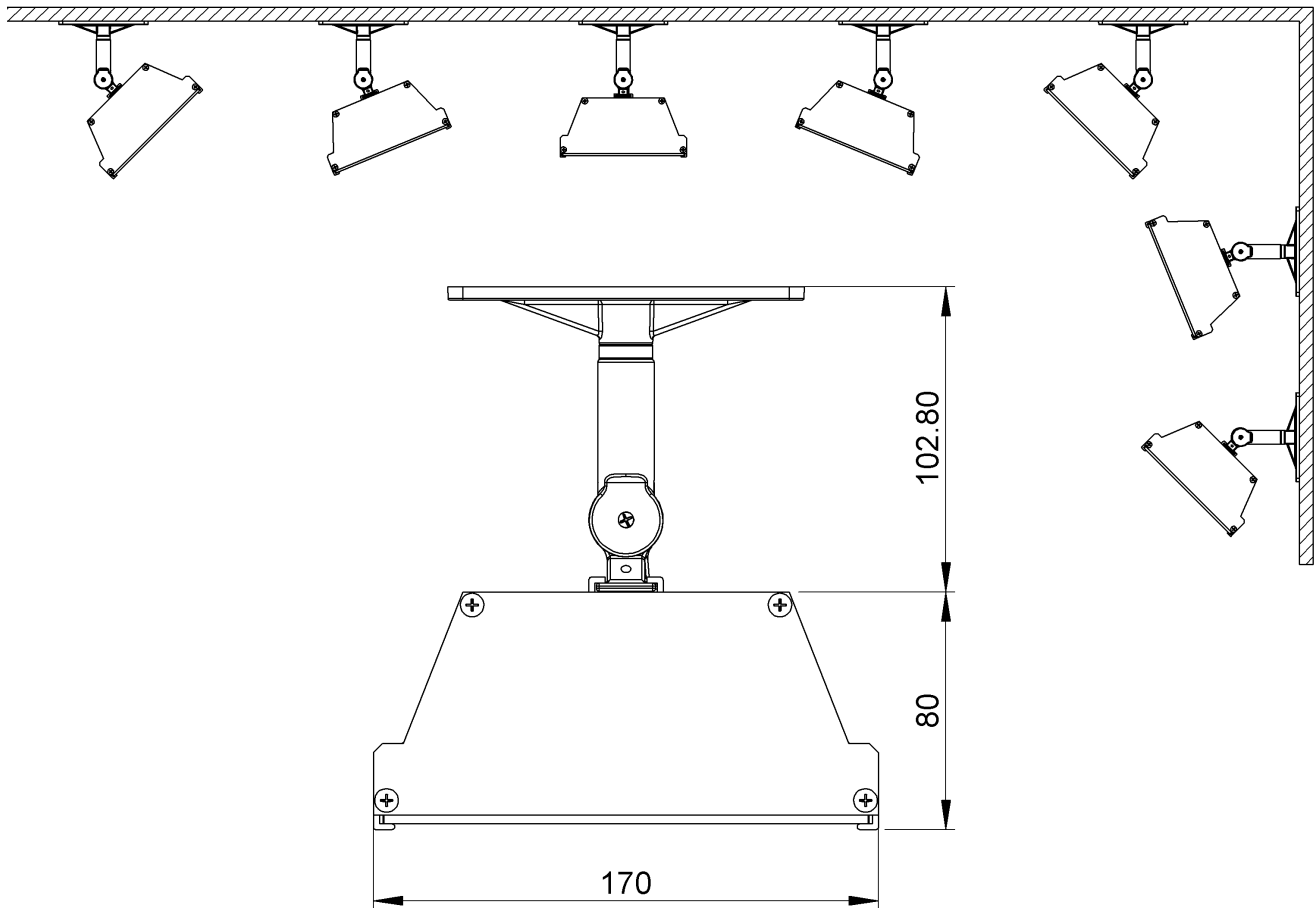

## Standard Mounting Bracket

PART No	PACKAGED DIMENSIONS (mm)	WEIGHT (kg)	MATERIALS
ZBRAK-132B	125 x 100 x 40	0.2	ALLOY



## MOUNTING

Fix the two mounting brackets to the ceiling or wall in the desired location (refer minimum bracket centre chart). Make sure the method of fixing (bolts or screws) will be more than strong enough to support the weight of the heater, allowing for strong winds and other conditions.

- Slide the 2 locking brackets into the groove on the back of the heater. Make sure the pins on the locking bracket are facing the matching holes in the top mounting bracket.
- Lift heater into position and secure the 2 locking brackets to the mounting brackets using the screws provided. Make sure the 2 pins on the locking bracket engage with the matching holes in the mounting bracket. The pins will allow for both horizontal or angle mounting as required
- Tighten all screws and tighten the round nut at the top of the bracket, so it locks onto the top part of the mounting bracket.

NOTE: the standard bracket allows for normal or angle mounting of the heater and is suitable for ceiling or wall mounting.

MODEL	"B" MINIMUM DISTANCE (mm)
THX2400DCR	400
THX3600DCR	600

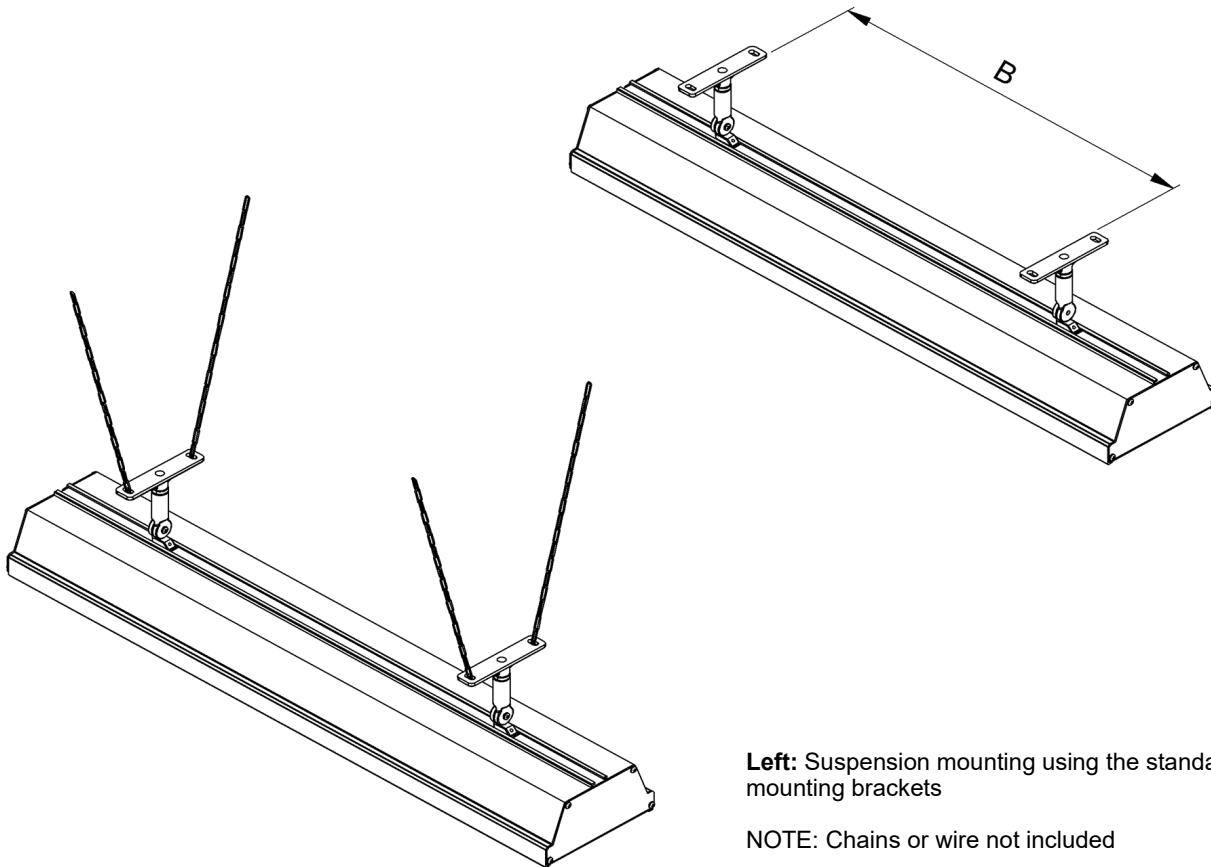

**Left:** Suspension mounting using the standard mounting brackets

NOTE: Chains or wire not included



## Extension Mount Bracket

The Extension Mount bracket allows HEATSTRIP® Max DCR units to be lowered from high ceilings, using rigid connections. The brackets are designed to be used with 20mm x 1mm round tube (SHS), and supplied as a complete kit that attaches to standard mounting brackets supplied with the heater. The standard length options as part of the kit are 150mm, 300mm, 600mm, 900mm and 1200mm.

Note: Standard brackets provided with the HEATSTRIP Max DC with Remote heaters is required when using the extension mounting poles. \*screws to ceiling are not included

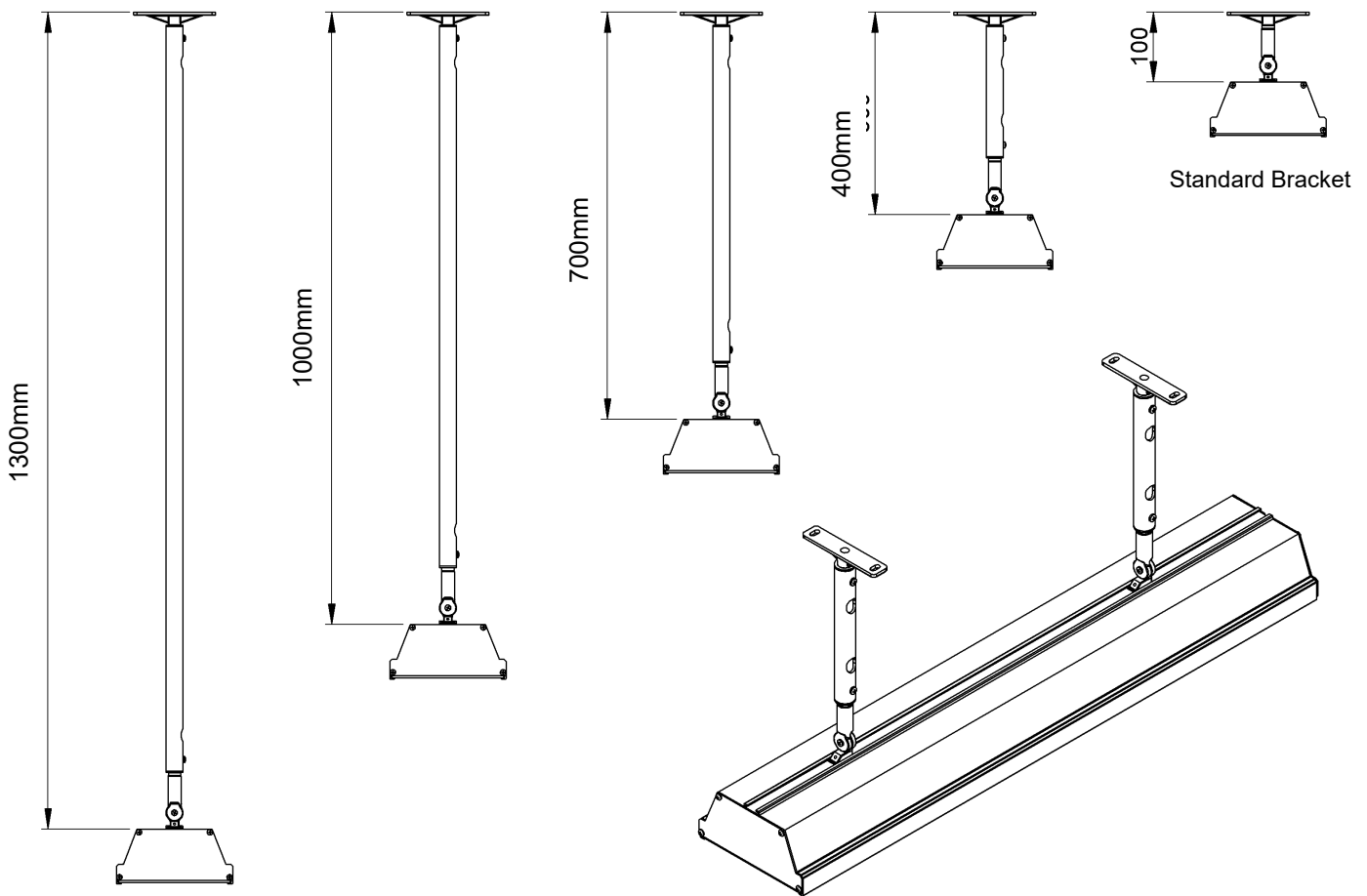

PART No	PACKAGED DIMENSIONS (mm)	WEIGHT (kg)	MATERIALS	NOTES
THYAC-047	300 x 150 x 50	0.21	Alloy	Kit includes 2 x 300mm extension poles, Black
THYAC-048	600 x 150 x 50	0.38	Alloy	Kit includes 2 x 600mm extension poles, Black
THYAC-049	900 x 150 x 50	0.55	Alloy	Kit includes 2 x 900mm extension poles, Black
THYAC-050	1200 x 150 x 50	0.71	Alloy	Kit includes 2 x 1200mm extension poles, Black



## Flush Mount Enclosure

The Flush Mount Enclosure is an ideal way to neatly install the HEATSTRIP® Max-DC with Remote into a ceiling. They are available for both HEATSTRIP® Max DC with Remote models, and are supplied as a one-piece unit for mounting of heaters. Flush mounting can be used with plaster or wood lined ceiling materials.

An ideal mounting height is 2.4m - 2.8m, with a maximum ceiling height of 3.5m in an indoor environment. Maximum mounting heights should be strictly followed, otherwise the performance of the units may be reduced.

The fascia of the enclosure is matte black and the rear casing is black zinc coated steel. Please refer to the Installation Manual for more detailed installation information.

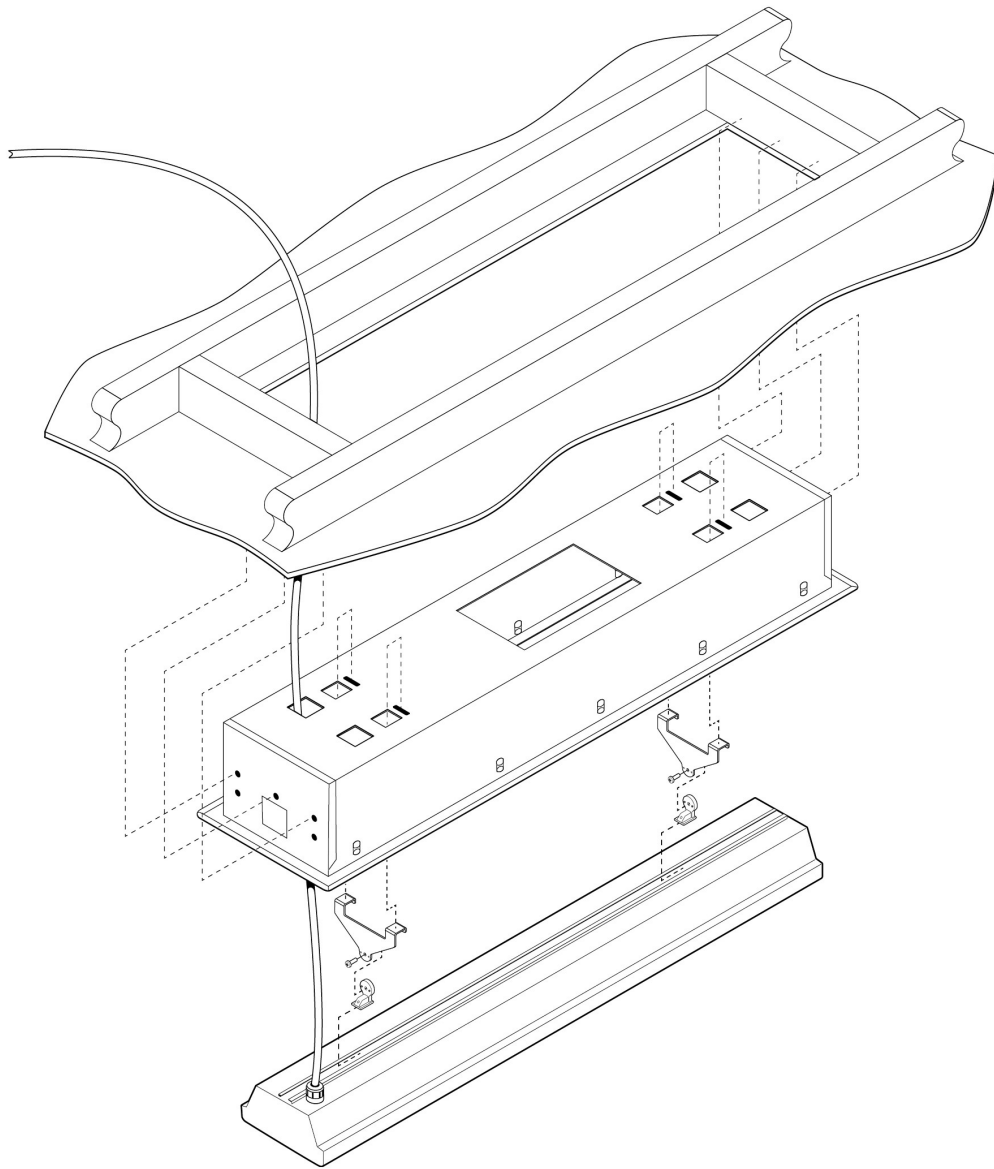

SUITABLE FOR MODELS	PART No	HOLE CUTOUT DIMENSIONS (mm)	OVERALL DIMENSIONS (mm)	WEIGHT (kg)
THX2400DCR	THXAC-030	-	-	-
THX3600DCR	THXAC-033	-	-	-



## HEATSTRIP<sup>®</sup> Max DC with Remote

The THXDC-R is a custom designed and manufactured heater. It has been designed for ease of use and provide low running cost of your heater. It provides 4 levels of temperature control, Adjustable set timer option from 0-24 hours with the touch of a button.

When the heater is plugged in or hardwired , press “power” on the remote, the power indicator light on the unit will light up and indicate the L1, L2, L3 using the + or - to change the heat settings, To set the timer click through the 0-24 hour timer .

### THXDC-R Functions

The heater temperature control L1 is the lowest heat setting and L3 is the highest heat setting.

The timer function has 0-24 hour timer. This feature is ideal for applications such as alfresco areas, restaurant dining, assembly line production etc. when continuous heat is not required. The timer also reduces the likelihood of heaters being inadvertently left turned on.

### Remote pairing

All units operate using the same remote control frequency, therefore, multiple heaters can be operated using a single remote control. The remote will function at distance of over 8m when used in a straight line. This distance reduces when used at an angle.

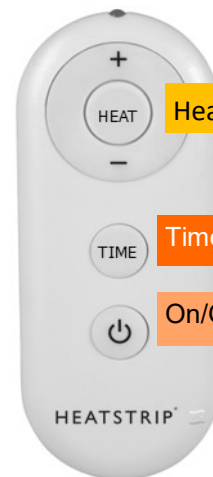

Remote battery	2x AAA batteries (Not included)
Remote range	10m
Wall socket supply	220V — 240V, 50Hz
Max load	10A (2400W) 15.5A (3600)
Standby consumption	<1W
Remote frequency	38kHz IR





## Remote Control Operation

### Signal Transmitter

- To use the remote controller, aim the transmitter to the heater. A line of sight transmission is required for the unit to function.
- The controller does not have a protection rating. The controller must be kept away from wet applications.
- The remote will function at distances of over 8m when used in a straight line. This distance reduces when used at an angle.

Receiver is located on the heater.



LED / control panel

### Temperature Control Button

- Temperature will be adjusted from L1-L2-L3
- The temperature will range from High to Low

### Timer

- Timer function 0-24 hour, press through to set timer

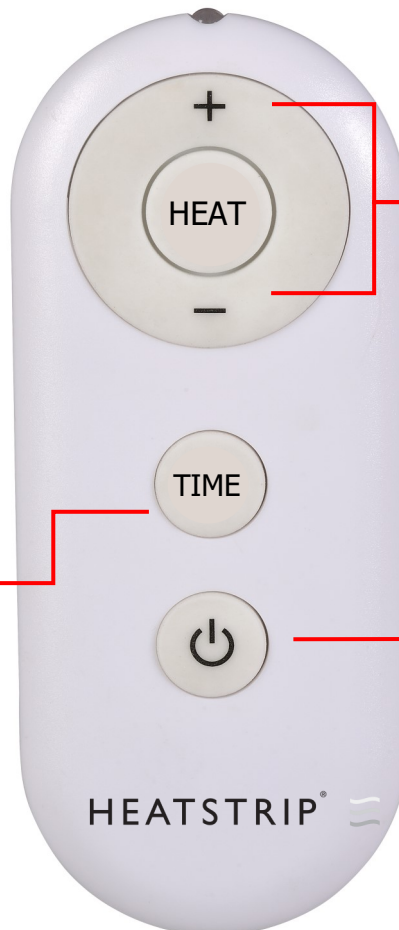

### On/Off Button

- Press this button once to turn on/off for operation

### Battery

- AAA Battery required for operation.



## Safety

HEATSTRIP® Max DCR has an IP rating of X5. This means it is safe for water ingress from all directions. The HEATSTRIP® can be safely hosed down. HEATSTRIP® has undergone extensive testing both in laboratory conditions; in Thermofilm's manufacturing facility in Melbourne and field trials in Australia and overseas. It has been this testing that gives the purchaser the confidence of a high quality product.

Independent laboratory testing has confirmed Thermofilm's full compliance with Australian and other International Standards. This includes CE, AS/ANZ, UL/CSE

The heater comes in both plug (2400W) and hardwired (3600W) versions. In both cases the fixed wiring must be installed by a licensed electrician in accordance with the relevant wiring regulations.

HEATSTRIP® is Class 1 equipment and must be earthed.

In operation, this heater is VERY HOT— do not touch any part of the heater while it is turned on. Do not touch any part until 30 minutes after it is turned off.

This appliance is not intended for use by persons (including children) with reduced physical, sensory or intellectual capabilities, or lack of experience and knowledge, unless they have been given supervision or instruction concerning use of the appliance by a person responsible for their safety. Children should be supervised to ensure they do not play with the appliance.

Do not allow any cables, furnishings, flammable materials or other items come in contact with any surface of the heater.

If installed in wet areas, the heater switches or controls must be located so that they cannot be touched by persons in the bath or shower.

The heater needs to be installed as per the installation instructions paying special attention to the minimum clearances. The heater needs to be mounted on a rigid bracket or fixing.

The heater must not be mounted immediately below or in front of a socket outlet.

In case of a heater fault or damaged supply lead, the appliance should be returned to the point of purchase for return to Thermofilm for repair.

## Maintenance

The HEATSTRIP® is made from durable materials, however regular care and maintenance of your heater will help prolong the life of the heater.

It is recommended that you hose down the heater and with a soft cloth gently wipe the surfaces of the heater with a mild detergent to remove the built up contaminants from the environment. Then rinse all detergent off the heater. All chemicals in the atmosphere including cigarette smoke, pollution etc. will tarnish the surface of the heater. In this case, additional cleaning and maintenance may be required. The cleaning process at least every three months will reduce the amount of build up and keep it looking as best it can. If the heater is in a corrosive environment eg. salt spray, we recommend that you clean your heater with a light spray of fresh water every week. After cleaning, turn the heater on for 20 minutes to dry any water residue and prevent water staining. Before cleaning or inspection activity, the heater must be switched off and cooled down completely. Do not use any abrasive materials or products to clean the heater, this includes solvents, citrus based cleaners or other harsh cleaning products.

When handling the heater, ensure that your hands are clean or that you use clean gloves as grease or dirt can mark the surface of the heater.

Do not use high pressure water to clean heaters, light water spray only.



## Warranty Terms & Conditions

The below Warranty Terms and Conditions apply for **New Zealand and Australia only**. For international warranty please refer to international warranty terms and conditions.

Thermofilm warrants to the original owner that HEATSTRIP® Max DCR products will be free from defects in materials and workmanship for a period of 24 months for residential applications and 12 months for commercial applications, from the date of purchase in accordance with the following warranty terms and conditions.

Provision of this warranty is subject to:

- The HEATSTRIP® product must be installed in accordance with the Installation Instructions and relevant electrical standards and codes.
- The HEATSTRIP® product must be maintained and cleaned according to instructions detailed in the Installation Manual.
- There is no warranty expressed or implied with regard to capacity requirements. The selection of the unit or units depends entirely upon the system design and capacities as determined by the purchaser.
- The customer has not repaired, opened or altered the product in any unauthorised manner.
- This warranty excludes damage to the product or components arising from circumstances outside the control of Thermofilm, including, but not limited to, where the product is not used for intended purpose; where the product has been rectified in any way; incorrect installation; incorrect power supply; damaged caused during delivery; misapplication, misuse, abuse, vandalism, lack of maintenance or accident.
- Thermofilm's obligations under this warranty are limited to repair or replacement at Thermofilm's factory of any components of the product which Thermofilm identifies to its satisfaction to be defective.
- Transportation charges involved in return of the product to the Thermofilm factory (or any other location authorised in writing by Thermofilm) is the sole responsibility of the customer.
- All products are inspected and tested before despatch and are at the risk of the purchaser after the shipment from the Thermofilm factory, if not delivered by Thermofilm to destination.
- Discolouration of the surface may occur after a period of time, this does not constitute a warrantable event.
- Twisting and bending of the heaters may occur, this does not constitute a warrantable event.
- No products or components will be supplied in advance of an examination of the faulty product or components by Thermofilm or an authorized representative of Thermofilm.
- Thermofilm does not participate in any site related costs or labour expenses incidental to replacement of parts, repairing, removing, installing, servicing, transportation or handling of parts to complete products, and assumes no liability on parts repaired or replaced without written authorisation. Thermofilm shall not be liable for any default or delay in performance of its warranty obligations caused by any circumstances beyond its control, including, but not limited to, judicial or government restrictions, strikes, fires, floods, abnormal weather conditions, delayed supply of components.

Should products be determined as damaged on arrival, immediately notify the transport company of the condition and have them noted on the freight documents. If damage is discovered after unpacking, demand immediate inspection by the transportation company and insist that a record of the damage is made on the freight documentation.

The customer warrants using the product in accordance with:

- Any instructions provided to it by Thermofilm from time to time.
- All government and local regulations, including but not limited to all relevant electrical, environmental laws and regulations governing the installation, storage, use, handling and maintenance of the goods.
- All necessary and appropriate precautions and safety measures relating to the installation, storage, use, handling and maintenance of goods.

*Our goods come with guarantees that cannot be excluded under the Australian Consumer Law. You are entitled to a replacement or refund for a major failure and for compensation for any other reasonably foreseeable loss or damage. You are also entitled to have the goods repaired or replaced if the goods fail to be of acceptable quality and the failure does not amount to a major failure.*

All warranty requests for repairs or replacements must be accompanied by a complete "Warranty Claim Form" available from Thermofilm, together with proof of purchase (and where possible, photos of the installation) and the heater returned to the place of purchase.

In the event of a warranty claim, the goods need to be returned to the distributor/retailer for repair/replacement. Contact  
 Thermofilm Australia Pty Ltd  
 17 Johnston Court, Dandenong South, Victoria 3175, Australia  
 Telephone: (03) 9562 3455,  
 Email: [info@thermofilm.com.au](mailto:info@thermofilm.com.au)